



# TECHNICAL CERTIFICATION RULES OF THE EUROVENT CERTIFIED PERFORMANCE MARK



## AIR TO AIR PLATE AND TUBE HEAT EXCHANGERS

Identification: ECP 08

Revision – 05-2020

(This version cancels and replaces any previous versions)

Approbation date: [28/05/2020](#)

**Comes into effect from: 28/05/2020**

The purpose of this Technical Certification Rules is to prescribe procedures for the operation of the Eurovent Certified Performance (ECP) certification programme for Air-to-air Plate and Tube Heat Exchangers (AAHE), in accordance with the Certification Manual.

Modifications as against last version:

No.	Modifications	Section	Page
1	New structure	all	all
2	Review of audit content	III.1.3.1	12-13
3	End of transition period for the audits	III.1.3.1	12
4	Update of surveillance procedure due to the new scheduling of the audits in quarter	B.2	27

This document is strictly reserved for use in the Certification Programmes of Eurovent Certita Certification. Reproduction or translation of any part of the document is forbidden without written permission from Eurovent Certita Certification.

Published by Eurovent Certita Certification  
48-50 rue de la Victoire  
75009 Paris, FRANCE

Tel: + 33 1 75 44 71 71  
E-mail: [q.liebens@eurovent-certification.com]

## TABLE OF CONTENTS

<b>I. GENERAL INFORMATION</b> .....	<b>5</b>
I.1 Scope .....	5
I.1.1 General .....	5
I.1.2 Certify-all principle .....	5
I.2 Certified performances.....	5
I.3 Definitions .....	5
I.4 Contributors.....	7
I.4.1 Audit body .....	7
I.4.2 Independent laboratory / test body .....	7
<b>II. REQUIREMENTS OF THE REFERENCE DOCUMENT</b> .....	<b>8</b>
II.1 Reference documents .....	8
II.1.1 Product and test standards .....	8
II.1.2 Specific Software requirements .....	8
II.2 Marking.....	9
II.2.1 Use of the certification mark by the Eurovent Certita Certification .....	9
II.2.2 Use of the certification mark by the Participant .....	10
<b>III. CERTIFICATION PROCESS</b> .....	<b>11</b>
III.1 Admission procedure .....	11
III.1.1 Declaration of data .....	11
III.1.1.1 Rated performance data .....	11
III.1.1.2 Certification forms.....	11
III.1.2 Admissibility of the application .....	11
III.1.2.1 General Procedure (for Original Equipment Manufacturers).....	12
III.1.2.2 Procedure for Brand Name companies .....	12
III.1.3 Implementation of checking operations .....	12
III.1.3.1 Initial admission audit .....	12
III.1.3.2 Selection of units to be tested .....	14
III.1.3.3 Tests at the independent laboratory .....	14
III.1.3.4 Software checking procedure .....	14
III.2 Time limitation of acquisition and recovery of units .....	15
III.2.1 Time limitation of acquisition of unit .....	15
III.2.2 Recovering of units .....	15
III.3 Failure treatment .....	15
III.3.1 Initial test failure .....	15
III.3.2 Unit failure .....	15
III.3.3 Mean Value of Failure.....	16
III.3.4 Penalty test in case of high failure .....	16
III.3.5 Penalty test in case of Mean Value of Failure (MVF) .....	16
III.4 Challenge procedure.....	17
III.5 Surveillance procedure .....	17
III.5.1 Surveillance audit.....	17
III.5.2 Selection of units to be tested.....	17
III.5.3 Surveillance tests.....	17
III.5.4 Software checking procedure .....	17
III.6 Declaration of modifications .....	17
III.6.1 Changes concerning the participant .....	17
III.6.2 Changes concerning production entities.....	18
III.6.3 Changes concerning the quality organisation of the manufacturing and/or marketing process.....	18

III.6.4	Changes concerning the certified range .....	18
III.6.5	Changes concerning the certified product .....	18
III.7	Suspension/cessation conditions .....	18
III.8	Production identification and traceability.....	18
<b>APPENDIX A.</b>	<b>TECHNICAL APPENDIXES .....</b>	<b>19</b>
A.1	Purpose .....	19
A.2	Test standard.....	19
A.3	Test pre-quisites .....	19
A.4	Test specifications .....	19
A.5	Verification after test .....	21
A.6	Checking specifications .....	21
A.7	Consistency check of the performances for multiple units .....	22
A.8	Consistency check of the performances for combination of units .....	22
A.9	Acceptance criteria .....	22
A.10	Description of the NTU method .....	24
<b>APPENDIX B.</b>	<b>CERTIFICATION PROCESS AND SCHEDULE.....</b>	<b>26</b>
B.1	Admission procedure .....	26
B.2	Surveillance procedure .....	27
<b>APPENDIX C.</b>	<b>LABORATORY LIMITS.....</b>	<b>28</b>
C.1	For “usual” units.....	28
C.2	For small units .....	28
<b>APPENDIX D.</b>	<b>FORMS.....</b>	<b>29</b>
D.1	Form AAHE-1: Declaration file .....	29
D.2	Form AAHE-2: Technical data sheet (TDS) .....	29
D.3	Form AAHE-3: Software/DLL update record sheet .....	29
<b>APPENDIX E.</b>	<b>VOCABULARY.....</b>	<b>30</b>

## I. GENERAL INFORMATION

### I.1 Scope

#### I.1.1 General

This certification programme applies to all ranges of Air to Air Plate and Tube Heat Exchangers which are included in the certified public selection software of the Applicant/Participant.

The Applicant/Participant shall certify all models in the ranges, including:

- cross flow, counter-flow and parallel flow units
- all sizes
- all materials
- all airflow rates
- all edge lengths
- plate heat exchangers with humidity transfer

Combination of units (twin exchangers) are also included in the scope of the programme.

Heat exchangers with accessories such as bypass and dampers shall not be included.

The programme does not cover other types of Air to air heat exchangers like Rotary heat exchangers or Heat pipes.

#### I.1.2 Certify-all principle

Whenever a company participates in the programme for AAHE, all AAHE that are promoted by the applicant/participant to end-users, specifiers, trading companies, contractors by means of paper or electronic catalogue, price list or software within the scope of the programme, shall be certified, in accordance with these Technical Certification Rules. This includes all models in modular ranges.

For the AAHE programme the certify-all principle applies not only to Europe but to all markets.

### I.2 Certified performances

The following performance items shall be certified.

- Under standard conditions (20°C, 50% rel. humidity and 1.013 10<sup>5</sup> Pa - or 1.20 kg/m<sup>3</sup> density):
  - Airflow
  - Pressure drop
- Under winter conditions (warm air temperature: 25°C, 60% rel. humidity; inlet temperature of cold air: -3°C, 90% humidity)
  - Temperature efficiency dry [%]
  - Temperature efficiency wet [%]
  - Humidity efficiency for plate heat exchangers with humidity transfer [%]
- Under summer conditions for plate heat exchangers with humidity transfer (warm air temperature: 35°C, 50 % rel. humidity; inlet temperature of cold air: 25 °C, 50 % rel. humidity)
  - Temperature efficiency dry [%]
  - Temperature efficiency wet [%]
  - Humidity efficiency [%]

### I.3 Definitions

In addition to the definitions specified in the Certification Manual, the following definitions apply:

**Critical non-conformity:** A non-conformity is classified as critical when based on objective evidence:

- there is a significant risk to the product's conformity to specified requirements, or

- there is a significant risk on management system's ability to control the product's conformity to specified requirements, or
- there is systematic or repeated non-conformity to a specified requirement.

**Non-critical non-conformity:** A non-conformity is classified as non-critical when based on objective evidence:

- there is no significant risk to the product's conformity to specified requirements, or
- there is no significant risk on management system's ability to control the product's conformity to specified requirements, or
- there is no systematic or repeated non-conformity to a specified requirement.

**Air-to-Air Plate and Tube Heat Exchangers:** Heat exchanger designed to transfer thermal energy (sensible or total) from one air stream to another without moving parts. Heat transfer surfaces are in form of plates or tubes. This exchanger may have parallel flow, cross flow or counter flow construction or a combination of these.

**Product range:** Family of products of different size built according the same design and using the same selection procedure.

Plates dimensions:

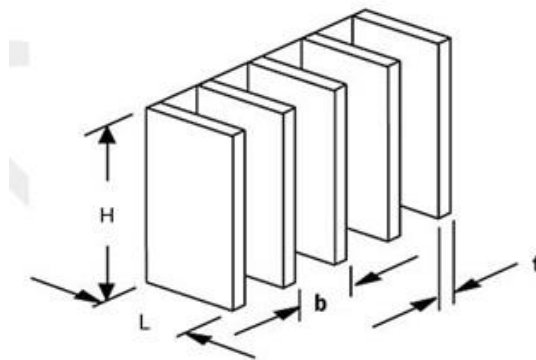

L = Plate length

H = Plate height

b = Plate spacing  
(plate interval + 1 plate thickness)

t = Plate thickness

**Temperature efficiency (temperature ratio) dry ( $\eta_t$ ) [%]:** Ratio of dry temperature differences:

$$\text{Eq. 1} \quad \eta_t = \frac{t_{22} - t_{21}}{t_{11} - t_{21}} \quad (\text{without condensation})$$

with: t      Temperature [°C]

11      Exhaust air inlet

12      Exhaust air outlets

21      Supply air inlets

22      Supply air outlets

**Temperature efficiency wet ( $\eta_{tw}$ ) [%]:** Ratio of dry bulb temperature differences when condensation occurs:

$$\text{Eq. 2} \quad \eta_{tw} = \frac{t_{22} - t_{21}}{t_{11} - t_{21}} \quad (\text{with condensation})$$

**Humidity (latent) efficiency ( $\eta_x$ ) [%]:** Ratio of absolute humidity differences:

$$\text{Eq. 3} \quad \eta_x = \frac{x_{22} - x_{21}}{x_{11} - x_{21}}$$

**Pressure drop (DP) [Pa]:** Loss in total pressure between the inlet and the outlet of a unit. It is mandatory to display in the outputs the pressure drop under the standard conditions. It is allowed to display any other pressure drop values if accompanied by the underlying air density.

**Internal air leakage:** Air leakage between two air streams.

**Air leakage (qmil/qmn) [%]:** Air leakage relative to nominal air flow.

**Nominal pressure drop (P<sub>nom</sub>) [Pa]:** Pressure drop at nominal conditions. The nominal pressure drop of each unit must be defined by the manufacturer. Possible values are 50 Pa, 100 Pa, 150 Pa or 200 Pa.

**Nominal air flow (NAF) [m<sup>3</sup>/h]:** Air flow which causes the nominal pressure drop. It is mandatory to display on the outputs actual exhaust and supply air flows.

#### **I.4 Contributors**

The lists of contributors are given for information and may be modified by EUROVENT CERTITA CERTIFICATION whenever necessary.

##### **I.4.1 Audit body**

The audit functions are performed by the following body(ies), called audit body:

**EUROVENT CERTITA CERTIFICATION SAS**

48/50 rue de la Victoire

F- 75009 PARIS

Tel : + 33 1 75 44 71 71

[www.eurovent-certification.com](http://www.eurovent-certification.com)

##### **I.4.2 Independent laboratory / test body**

When the checks carried out involve product tests, these are performed at the request of EUROVENT CERTITA CERTIFICATION by the following laboratories, known as Independent laboratory:

**HOCHSCHULE LUZERN TECHNIK & ARCHITEKTUR**

Technikumstrasse 21

CH-6048 – HORW

Switzerland

## II. REQUIREMENTS OF THE REFERENCE DOCUMENT

### II.1 Reference documents

#### II.1.1 Product and test standards

Performance ratings claimed by manufacturers shall be verified by tests performed in the independent laboratory selected by Eurovent Certita Certification.

The following standard shall be used as a basis for these tests:

EN 308:1997: Heat Exchangers - Test procedures for establishing performance of air to air and flue gases heat recovery devices.

#### II.1.2 Specific Software requirements

General software (selection tool) requirements are described in the dedicated appendix of Certification Manual. In addition:

- Each technical selection has to be reproducible without any protection by login and/or password.
- Vocabulary and symbols shall be in accordance with reference vocabulary available on the Eurovent Certified Performance website and in Appendix E.
- It is mandatory for the Applicant/Participant to provide, as inputs of the software:
  - the mass flows (as a mandatory option) on the building side (exhaust inlet and supply outlet);
  - the temperature on the entry sides (extract and supply inlet);
  - the humidity on the entry sides (extract and supply inlet).
- It is mandatory for the Applicant/Participant to display the following items as outputs and on the printouts:
  - the temperature efficiency (also called temperature ratio);
  - the pressure drop under standard conditions. Additionally, it is allowed to display any other pressure drop values if accompanied by the underlying air density;
  - the actual extract and supply outlet mass flows (at least).
  - all four airflows (inlet and outlet on both extract and supply sides).
  - Influence of the pressure difference on the pressure drop
  - Maximum pressure difference
- All airflows shall be given at standard density ( $1.2 \text{ kg/m}^3$ ) as a minimum. It is authorized to show any other volume flow (additionally) if accompanied by the underlying density. It is allowed to ask the location of the customer in the software, however all data provided by the software shall be the same whatever the location of the customer is.
- It is forbidden to display the Extract/Exhaust Air Temperature Efficiency and Humidity Efficiency in both outputs and printouts.
- All defined dimensional characteristics must be used explicitly in accordance to this TCR definitions and the mentioned wordings must not be used for other purposes.



SYMBOL	RECOMMENDED NAME	Output	Printout
	Type key		Mandatory
	Basic material		Mandatory <sup>(1)</sup>
$q_m$ $q_v$ $q_{vn}$	air mass flow rate or Standard air volume flow rate (1.2 kg/m <sup>3</sup> )	Mandatory	Mandatory
$p_a$	Atmospheric pressure		Mandatory
...11	Extract air [if Exhaust air is used] Exhaust air inlet <sup>(1)</sup> [if Exhaust air outlet is used]		Mandatory
$t_{11}$	Extract air temperature		Mandatory
$\varphi_{11}$	Extract air relative or absolute humidity		Mandatory
$q_{11}$	Extract air airflow		Mandatory
...21	Supply air inlet <sup>(1)</sup>		Mandatory
$t_{21}$	Supply air inlet temperature		Mandatory
$\varphi_{21}$	Supply air relative or absolute humidity		Mandatory
$q_{21}$	Supply air inlet airflow		Mandatory
...12	Exhaust air [if Extract air is used] Exhaust air outlet <sup>(1)</sup> [if Exhaust air inlet is used]	Mandatory	Mandatory
$t_{12}$	Exhaust air temperature	Mandatory	Mandatory
$\varphi_{12}$	Exhaust air relative or absolute humidity	Mandatory	Mandatory
$q_{12}$	Exhaust air airflow	Mandatory	Mandatory
...22	Supply air outlet <sup>(1)</sup>	Mandatory	Mandatory
$t_{22}$	Supply air temperature	Mandatory	Mandatory
$q_{22}$	Supply air airflow	Mandatory	Mandatory
$\Delta p_1$	Pressure drop on exhaust air side at standard condition (1.2 kg/m <sup>3</sup> )	Mandatory	Mandatory
$\Delta p_2$	Pressure drop on supply air side at standard condition (1.2 kg/m <sup>3</sup> )	Mandatory	Mandatory
$\eta_t$	Temperature efficiency dry [for plates] Temperature efficiency wet [for plates <i>without humidity transfer</i> ] Temperature efficiency [for regeneratives]	Mandatory	Mandatory
$\eta_x$	Humidity efficiency (plates with humidity transfer) Humidity efficiency (regenerative)	Mandatory	Mandatory

(1): the information can be found in the type key

Table 1: Information to be found as outputs and on the printouts

## II.2 Marking

It is highly recommended that the participating company indicates participation in the EUROVENT CERTIFIED PERFORMANCE (ECP) programme for Air-to-air Plate and Tube Heat Exchangers by the following means.

### II.2.1 Use of the certification mark by the Eurovent Certita Certification

For each certified model, the following general information, and certified performance and characteristics shall be published on the Eurovent Certified Performance website: [www.eurovent-certification.com](http://www.eurovent-certification.com) for Air-to-air plate and tube heat exchangers:

- Name of Company
- Trade name or brand name of model
- Production site(s) (city, country)
- Model designation(s)
- Range
- Selection software name and version
- Air flow [m<sup>3</sup>/h]
- Pressure drop [Pa]
- Temperature efficiency dry in winter conditions [-]
- Temperature efficiency wet in winter conditions [-]
- Temperature efficiency dry in summer conditions for exchangers with humidity transfer [-]
- Temperature efficiency wet in summer conditions for exchangers with humidity transfer [-]
- Humidity efficiency for exchangers with humidity transfer [-]
- Plate length [mm]
- Plate height [mm]
- Plate thickness [mm]
- Plate spacing [mm]
- Casing outside length [mm]
- Casing outside height [mm]
- Influence of the pressure difference on pressure drop

### **II.2.2 Use of the certification mark by the Participant**

See dedicated chapter in Certification Manual.

### III. CERTIFICATION PROCESS

#### III.1 Admission procedure

##### III.1.1 Declaration of data

In addition to the provisions laid down in the Certification Manual, the following requirements apply:

The Applicant, after signing the Certification Agreement, shall send to EUROVENT CERTITA CERTIFICATION all information required for the qualification: software name and version, the software itself, declaration file and relevant literature.

All characteristics and performance items shall be expressed in SI units unless otherwise specified by Eurovent Certita Certification.

Submittal of certification of models shall be sent to Eurovent Certita Certification as .xls or .xlsx declaration file. The following forms shall be fully completed:

- Declaration file AAHE-1:
  - for manufacturing companies (Original Equipment Manufacturer – OEM) to declare products, performances and technical data;
  - for Brand Name (BN) companies to identify the corresponding models number of the OEM.
- Technical data sheet AAHE-2 will be used to complete technical description of all raw material or basic components for the units selected.

All units shall be declared with an effective depth of 1000 mm in the declaration form AAHE-1. The effective depth corresponds to the depth of the exchanger “naked”, i.e. without casing.

Confidentiality of certification data: All data submitted to Eurovent Certita Certification shall be held confidential except for information authorised to be published in the website.

The Applicant/Participant shall inform Eurovent Certita Certification of any modification of models by updating declaration file and selection software by sending Software update record sheet AAHE-3. In the case of significant modifications Eurovent Certita Certification is entitled to request adequate tests to check the influence on performance data.

Starting with the 2019 campaign, the performances at 50% and 150% of the nominal pressure drop will be declared by the manufacturers and published on the ECP website.

##### III.1.1.1 Rated performance data

All characteristics shall be expressed in SI Units as a minimum. The manufacturer is authorized to display data from the selection software in non-SI units as an option.

##### III.1.1.2 Certification forms

Submittal of certification of models shall be completed and sent to Eurovent Certita Certification as .xlsx files. The forms shall be sent by e-mail to EUROVENT CERTITA CERTIFICATION within the time limits specified in Certification Schedule (see Appendix B – Campaign schedule, if applicable).

Copies of the forms are part of these Technical Certification Rules (see Appendix A):

- Declaration file AAHE-1 will be used.
- Technical data sheet AAHE-2 will be used to complete technical description of all raw material or incoming goods for the units selected.
- Software/DLL update record sheet AAHE-3 will be used

##### III.1.2 Admissibility of the application

Once the application is completed, the admission procedure is articulated as follows:

### III.1.2.1 General Procedure (for Original Equipment Manufacturers)

For Original Equipment Manufacturers (OEM), Eurovent Certita Certification:

- checks the software (or DLL) compliance to general (see Certification Manual) and specific (see C.1) requirements and its consistency with the declaration file provided with the Applicant;
- audits all the production sites
- proceeds to the selection of the models to be tested in the independent laboratory based on the declaration file AAHE-1;
- orders the product performances testing to the independent laboratory;
- performs a “test-check” to evaluate the test success.

If the checks prove the products compliance with the requirements specified in this TCR, the certification is granted. If not, the procedure for failure treatment shall be applied.

When certified, the products are published on the Eurovent Certified Performance (ECP) website as specified in section II.2. Once the certificate is received, the participant is entitled to use the certification mark according to applicable requirements (see section II.2.2).

### III.1.2.2 Procedure for Brand Name companies

For Brand Name (BN) companies, Eurovent Certita Certification conducts checks of the software (or DLL) compliance to general (see Certification Manual) and specific (see C.1) requirements and its consistency with the declaration file provided with the Applicant.

## III.1.3 Implementation of checking operations

The provisions of the Certification Manual apply.

### III.1.3.1 Initial admission audit

#### a. General

General audit requirements are stated in the Certification Manual. An audit long one (1) working day (8 hours) for one production site.

The objective of an audit is to make sure that the Applicant/Participant produces and delivers what is promoted in the software, documentation or any other material. In particular it shall focus on any advertising and manufacturing process that has an influence on the certified performances.

The audits will consist on the verification that the applicable requirements specified in the paragraph III.1.3.1 are fulfilled.

If the audits are not conducted within the time limitations specified in the notification received from Eurovent Certita Certification, it is considered as a non-application of procedures.

In case of force majeure (e.g. accidents, labour disputes, natural events, acts of war) which would not allow Eurovent Certita Certification to perform a factory audit Eurovent Certita Certification can decide to replace it by another mean of verification, to postpone it within a reasonable deadline or to cancel it.

#### a. Audit requirements

During the audit, the auditor will check:

- that the ECP mark is displayed on the produced units and on the documentation in compliance with the requirements defined in the Certification Manual and Technical Certification Rules;
- that the products in the *catalogue (or website)/software* are compliant with the declaration list;
- that the corrective actions plan *from the previous audit* is completed.

The auditor shall also perform a review of performance related items in the Quality Management System (QMS) to check:

- that the suppliers are regularly evaluated and that the corresponding evaluations are recorded;
- that the following checks are performed on incoming raw materials:

Item to be checked	Frequency	Acceptance criteria
Foil thicknesses ( <i>aluminum &amp; plastic</i> ) ( <i>without sorption coating</i> )	1 / lot	7%

- that the related material (e.g. foil, desiccant, sealing) or incoming goods conformity with the bill of material (BOM) specifications is regularly evaluated and that the corresponding evaluations are recorded;
- that the manufacturing process key steps are submitted to a validation check (e.g. defined in the QMS). In particular for each item listed in the table below, *the manufacturer shall ensure that*:
  - measurement methods are reliable;
  - measurements are recorded.
  -

Item to be checked	Frequency	Acceptance criteria
Package Height	1 / batch <sup>1</sup>	As per TCR
Package Length	1 / batch <sup>1</sup>	As per TCR
Plate Spacing on final product	1 / batch <sup>1</sup>	As per TCR
Package width	1 / batch <sup>1</sup>	As per TCR

<sup>1</sup> A batch is a group of similar units produced at the same time (in series), using the same process and under the same setup of the production line.

*The auditor will check the items of the table above on a sample of two units (three if necessary) from different models in the production.*

- that the factory personnel is qualified to perform the specific tasks if any (*competence shall be recorded*);
- *that to ensure the traceability of the products each certified product shall be marked with respect to the plant (e.g. serial number)*;
- the regularity of the calibration of measuring devices;
- that production non-conformities are recorded and corrective actions initiated;
- that customers complaints are registered and treated (for both Original Equipment Manufacturer (OEM) and Brand Name (BN));
- that the delay for the distribution of the selection programme is described (e.g. in the QMS) (maximum 1 month *from the date the software is approved by ECC*);
- that the sealing material and configuration is in accordance with the declaration.

#### **b. Audit non-conformity**

After evaluation, a non-conformity is classified as critical when, on the basis of objective evidence, the following cases are identified:

- there is a significant risk to the product conformity with respect to specified requirements;
- there is a significant risk regarding the quality management system ability to control the product conformity to specified requirements;
- there is systematic or repeated non-conformity to a specified requirement;

Otherwise the non-conformity is classified as not-critical.

In case of a non-conformity, the applicant/participant shall be requested to provide Eurovent Certita Certification with a corrective action plan within the deadline specified by the auditor.

Unless otherwise indicated by the auditor:

- any critical non-conformity shall be corrected within a maximum delay of four weeks;
- any non-critical non-conformity shall be corrected no later than the next factory audit.

### **III.1.3.2 Selection of units to be tested**

In addition to the provisions laid down in the Certification Manual, the following requirements apply: EUROVENT CERTITA CERTIFICATION shall select units to be tested based on its evaluation of the declaration file AAHE-1 communicated by the applicant.

For the qualifying procedure, three units, if existing, of different sizes and if possible different spacing shall be selected from the range by Eurovent Certita Certification and tested.

Eurovent Certita Certification can select the production sites from which the unit will be delivered if several production sites are declared by the participant.

### **III.1.3.3 Tests at the independent laboratory**

In addition to the provisions laid down in the Certification Manual, the following requirements apply:

Before testing, the laboratory shall check the product against the information declared in the technical datasheet to ensure that the unit corresponds to the selection.

The laboratory shall not perform the test and contact EUROVENT CERTITA CERTIFICATION when:

- one of the information is not compliant with the technical datasheet (see Appendix A),
- one of the units appears damaged

EUROVENT CERTITA CERTIFICATION will contact the applicant to give instructions regarding further actions.

Tests shall be performed at the Independent laboratory selected by EUROVENT CERTITA CERTIFICATION.

The laboratory shall be responsible for uncrating, handling, testing and recrating the unit for shipment. Only the independent laboratory personnel shall be permitted to handle test units.

The Applicant/Participant shall provide to the laboratory full information about the installation. Units shall be installed in test facility in accordance with the Applicant/Participant's published installation instructions.

No Applicant/Participant's personnel shall be present in the test facility during the measurements.

#### **c. Test conditions**

The units shall be tested at the conditions as stated in Appendix A.

#### **d. Test report and tests results**

Upon completion of the test on each unit, the laboratory will render its complete report as pdf file to Eurovent Certita Certification, which will immediately forward it to the Participant.

For each performance item, deviation is calculated as the difference between claimed value (calculated using the selection software under the test conditions) and result of test in the independent laboratory. When completed, Eurovent Certita Certification shall transmit to the Participant the results of the checking and conclusions (Form AAHE-4).

If all deviations are inside the allowed acceptance criteria, the test is considered as "Passed". If at least one deviation is out of allowed acceptance criteria, the test is considered as "Failed" and the procedure for failure treatment (section III.3) shall be applied.

### **III.1.3.4 Software checking procedure**

In addition, with the general software requirements which are described in the dedicated appendix of the Certification Manual, the software must comply with the requirements described in the section II.1.2).

- The performances shall be consistent: with the declaration file AAHE-1;
- with one another (see consistency rules in the Appendix A).



## III.2 Time limitation of acquisition and recovery of units

The provisions of the Certification Manual apply.

### III.2.1 Time limitation of acquisition of unit

Deadline for delivery of units to the laboratory, together with the technical data sheet completed and the payment shall be decided by Eurovent Certita Certification in accordance with the Programme committee.

If elements are not delivered within the time limitations (specified in the notification received from Eurovent Certita Certification), it is considered as non-application of procedures (see dedicated chapter in Certification Manual).

### III.2.2 Recovering of units

Applicant/Participant shall recover its products four working weeks after receiving its test report and results. When the units are not recovered on time, the laboratory can destroy the units and the invoice shall be sent by Eurovent Certita Certification to the Applicant/Participant.

## III.3 Failure treatment

### III.3.1 Initial test failure

As defined in the Certification Manual (latest version in force), is considered as an initial test failure any situation where:

- the unit to be tested cannot be operated, or
- any functional component of the unit to be tested is out of order
- the unit to be tested, or any of its components is damaged, e.g. due to transportation.

The applicant/participant shall then send a new unit of the same model. In specific cases, products or components can be repaired at the laboratory, under the responsibility of the manufacturer and the supervision of the laboratory.

If internal air leakage or dimensions of the unit are outside the acceptance criteria defined in the this TCR (latest version in force), the laboratory shall stop the test. In both cases, the laboratory shall inform Eurovent Certita Certification and the technical contact of the Applicant/Participant. The laboratory may make repairs to the test unit only in agreement with Eurovent Certita Certification and the Applicant/Participant.

The laboratory will send a short report to Eurovent Certita Certification, explaining why the unit could not be tested. A further unit shall then be delivered within 4 weeks for test.

### III.3.2 Unit failure

After a failure, the applicant/participant shall examine the reasons of the failure.

If a failure occurred, the Applicant/Participant has four working weeks from the notification of failure to choose one of the following alternatives:

- 1) Rerate the data, by adapting the selection software to the test results. The corrected software with its new version number shall be sent to Eurovent Certita Certification who will check the consistency of the modifications. If the software is in accordance with all the measurements, new selection documentation with a new reference and date of publication shall be put on the Eurovent Certified Performance website. After reverification (“test recheck”), if the software is still not in accordance with the test results manufacturer will have two additional weeks for final adjustment of the software. In case of new failure, the Participant shall be temporarily suspended until he updates his software in accordance with the tests results.
- 2) Ask for a second test on the same unit after analysis of the non-conformity and implementation of actions if applicable. If this second test is successful, no revision of selection software will be required. If the second test is unsuccessful, the Participant shall comply with point (1). When the second test is carried out on another unit that the one already tested, then penalty test will be required.

If the failure is confirmed and accepted by the Applicant/Participant for

- at least 2 failures over the 7 measurements for AAHE without humidity transfer
- at least 4 failures over the 24 measurements for AAHE with humidity transfer

of a test of campaign n, a penalty test will be required on a unit from the same factory in test campaign n+1. Only one penalty test per test can be required.

### III.3.3 Mean Value of Failure

Mean Value of Failure (MVF) is equal, for each manufacturer, to the ratio between the total numbers of measurements of all the considered characteristics above intermediate deviations and the total performed measurements in the considered years. It is calculated as follows:

$$MVF = \frac{\sum_{3 \text{ years}} N_{performances \text{ failed}}}{\sum_{3 \text{ years}} N_{performances \text{ tested}}}$$

One global value will be considered. The following certified performances are considered:

- Nominal Pressure Drop (100%)
- 50% of nominal Pressure Drop
- 150% of nominal Pressure Drop
- Temperature efficiency dry at nominal Pressure Drop
- Temperature efficiency dry at 50% of nominal Pressure Drop
- Temperature efficiency dry at 150% of nominal Pressure Drop
- Temperature efficiency wet at nominal Pressure Drop

Should be considered for the calculation of the MVF any results of the above list of performances out of the acceptance criteria defined in this TCR (latest version in force).

The following calendar will be followed for the next 3 years:

- End of year 2019: assessment of the MVF based on years 2018-2019 with a MVF threshold of 35%
- End of year 2020: assessment of the MVF based on years 2018-2019-2020 with a MVF threshold of 30%
- End of year 2021: assessment of the MVF based on years 2019-2020-2021 with a MVF threshold of 25%

Then from 2022 calculation of the MVF will be based on the results of the past 3 years with a threshold of 25%.

### III.3.4 Penalty test in case of high failure

In case of high failure (as defined in the Appendix A) on one of the following performances: Pressure drop, temperature efficiency (dry and wet), or humidity efficiency, a penalty test will be required on a unit from the same factory in test campaign n+1. Only one penalty test per test can be required.

### III.3.5 Penalty test in case of Mean Value of Failure (MVF)

Should the MVF be higher than:

- 35% in 2019
- 30% in 2020
- 25% in 2021 and following years

3 additional units shall be selected and tested with a high priority in the same campaign.

The manufacturer shall show that the actions implemented are efficient to lower significantly the failure rate by having, on each of the 3 tests, a failure rate below 15% and no high failure. Should this requirement not be fulfilled, the participant shall be suspended, and a new selection of 3 units shall be made.



### **III.4 Challenge procedure**

Under special conditions a challenge procedure may be carried out, as described in the Certification Manual.

### **III.5 Surveillance procedure**

The provisions of the Certification Manual apply.

Every year Eurovent Certita Certification checks whether the certified products still fulfil the requirements:

- For Brand Name (BN) companies, applicable requirements of the software/DLL shall be fulfilled
- For Original Equipment Manufacturers (OEM), the following steps are conducted annually in compliance with the Certification Schedule (see Appendix A):
  - check of the software (or DLL) consistency with the declaration file provided by the participant;
  - audits of all production sites (see section III.1.3.1)
  - selection (see section III.1.3.2) of the models to be tested in the independent laboratory based on the declaration file;
  - order of the product performance testing to the independent laboratory;
  - “test-check” (see III.1.3.4) to evaluate the test success.

For the surveillance procedure, the certification is renewed at the date specified in the Certification Schedule (see **Erreur ! Source du renvoi introuvable.**) on condition that:

- The previous test campaign (N-1) has been successfully completed;
- The scheduled audits have been performed by the auditor and are successful or the corrective actions plan is considered satisfactory;
- The selected product together with the technical datasheet delivery and the payment have been completed.

The company receives then a renewed certificate and the display of data is renewed on the Eurovent Certified Performance (ECP) website. If not, failure treatment shall be applied.

#### **III.5.1 Surveillance audit**

The provisions laid down in the initial admission audit (section III.1.3.1) apply for the surveillance audit.

#### **III.5.2 Selection of units to be tested**

In addition to the provisions laid down in the Certification Manual, the following requirements apply:

For the surveillance procedure, one unit for all certified ranges shall be selected by Eurovent Certita Certification every year and tested.

Eurovent Certita Certification can select the production sites from which the unit will be delivered if several production sites are declared by the participant.

In case of a model selected was the same than in a previous test campaign, the Participant shall manufacture and provide a new physical unit.

#### **III.5.3 Surveillance tests**

The provisions laid down in the admission procedure (section III.1.3.3) apply for the surveillance audit.

#### **III.5.4 Software checking procedure**

The provisions laid down in the admission procedure (section III.1.3.4) apply for the surveillance audit.

### **III.6 Declaration of modifications**

The provisions of the Certification Manual apply.

#### **III.6.1 Changes concerning the participant**

The provisions of the Certification Manual apply.

### **III.6.2 Changes concerning production entities**

The provisions of the Certification Manual apply.

### **III.6.3 Changes concerning the quality organisation of the manufacturing and/or marketing process**

The provisions of the Certification Manual apply.

### **III.6.4 Changes concerning the certified range**

The provisions of the Certification Manual apply.

### **III.6.5 Changes concerning the certified product**

In addition to the provisions laid down in the Certification Manual, the following requirements apply:

The applicant/participant shall inform Eurovent Certita Certification of any modification of the product portfolio by updating the declaration file (AAHE-1) and sending the updated selection software together with the software update record sheet AAHE-3.

### **III.7 Suspension/cessation conditions**

The general consequences of non-application of procedures are described in Certification Manual.

### **III.8 Production identification and traceability**

The participant shall use suitable means to identify the products by a unique identification code (the minimum traceable information: production plant, N° of lot, components), and the retention of documented information (records) necessary to enable traceability.

## APPENDIX A. TECHNICAL APPENDIXES

### A.1 Purpose

The purpose of these Technical appendixes is to establish definitions and specifications for testing and rating of Air-to-air Plate and Tube Heat Exchangers for the related Eurovent Certified Performance Programme, in accordance with these Technical Certification Rules.

### A.2 Test standard

Performance ratings claimed by manufacturers shall be verified by tests performed in the independent laboratory selected by Eurovent Certita Certification.

The following standard shall be used as a basis for these tests:

EN 308:1997: Heat Exchangers - Test procedures for establishing performance of air to air and flue gases heat recovery devices.

### A.3 Test pre-quisites

Before testing, the laboratory shall check outer dimensions and air leakage. The following acceptance criteria are acceptable:

- Dimensions: +/- 2mm
- Plate spacing: +/- 1% or +/- 1 plate

If a unit is not corresponding to the ordered dimensions, the laboratory shall not perform the test and contact Eurovent Certita Certification who shall ask the Participant to send a new unit.

Air leakage shall be checked according to EN 308:1997 and noted (in % with 1 decimal place; normally rounded). The following acceptance criteria are acceptable:

- Air leakage
  - + 0.5 % for models without humidity transfer
  - + 1.0 % for models with humidity transfer

All units must be tested under a pressure difference of 250 Pa. If a unit is not compliant with the above maximum leakages, it is considered as a component failure. The laboratory shall stop the test and contact the Participant to repair or send another unit. In case the failure is caused by the design of the unit (regular production), the unit shall be removed from the selection software.

### A.4 Test specifications

The units shall be tested under the EN 308:1997 conditions.

- The following particular specifications shall be applied during the test in the independent laboratory selected by Eurovent Certita Certification.
- Pressure drop shall be measured at a pressure difference equal to five times the nominal pressure drop. The obtained value will be called "Influence of pressure difference on pressure drop". If a unit cannot resist the "Influence of Pressure Difference on Pressure Drop" test, the Nominal Pressure Drop shall be related to a lower value so that the exchanger can bear five times the nominal pressure drop as a pressure difference. If the Nominal Pressure Drop is already 50 Pa, then the exchanger cannot be certified, and thus cannot be included in the selection software.
- Pressure drop shall be measured for at least three air-flow rates corresponding to the pressure drop of 50, 100 and 150% of the nominal pressure drop, each +/- 10%, at least +/- 5 Pa.
- Temperature efficiencies (dry or wet) and humidity efficiency shall be measured for three air-flow rates corresponding to 50, 100 and 150% of the nominal pressure drop, each +/- 10%, at least +/-5 Pa.

These last two bullet points result in the following table.

© 2015 – Eurovent Certita Certification SAS – All rights reserved

Possible nominal pressure drop [Pa]		50	100	150	200
Corresponding nominal air flow [m <sup>3</sup> /h]		NAF <sub>50</sub>	NAF <sub>100</sub> or Q <sub>mn</sub>	NAF <sub>150</sub>	NAF <sub>200</sub>
500% P <sub>nom</sub>	Pressure difference [Pa]	250	500	750	1000
50% P <sub>nom</sub>	50% of nominal pressure drop [Pa]	25	50	75	100
	Acceptable deviation [Pa]	+/- 5	+/- 5	+/- 7.5	+/- 10
100% P <sub>nom</sub>	100% of nominal pressure drop [Pa]	50	100	150	200
	Acceptable deviation [Pa]	+/- 5	+/- 10	+/- 15	+/- 20
150% P <sub>nom</sub>	150% of nominal pressure drop [Pa]	75	150	225	300
	Acceptable deviation [Pa]	+/- 8	+/- 15	+/- 22.5	+/- 30

Table 2: Possibilities of air-flow conditions and associated acceptable deviations

- Winter test for efficiency with condensation shall be performed under the following conditions:
  - The nominal pressure drop (without condensation, +/- 10%, at least +/-5 Pa) for plate heat exchangers with and without humidity transfer
  - 50 and 150% of nominal air flow for plate heat exchangers with humidity transfer (see table above)
  - The mass flow ratio of 1.0
  - The warm air temperature of about 25°C with a humidity ratio between 45% and 75%. The inlet temperature of cold air at 0°C to -5°C (humidity is not defined.)
- Fixed summer test for efficiency shall be performed under the following fixed conditions for plate heat exchangers with humidity transfer:
  - The nominal pressure drop, 50 and 150%
  - The mass flow ratio of 1.0
  - The warm air temperature of about 35°C with randomly one of the following humidity conditions: 50% relative humidity. The inlet temperature of cold air at 25°C and 50% humidity.
- Random summer test for efficiency shall be performed under the following conditions for plate heat exchangers with humidity transfer:
  - The nominal pressure drop
  - The mass flow ratio of 1.0
  - The warm air temperature of about 35°C with randomly one of the following humidity conditions: 14-22 g/kg. The inlet temperature of cold air at 25°C and 50% humidity.
- All efficiencies (in percent) shall be measured at a mass flow ratio of 1.0 with 1 decimal place and rounded normally.

The following table summarizes the testing conditions and related tested performances

Product type	Any type (regular point)	Without humidity transfer	With humidity transfer			
			Winter "dry"	Winter "condensation"	Summer "dry"	Summer "random"
Conditions	Winter "dry"	Winter "condensation"	Winter "condensation"	Summer "dry"	Summer "random"	
Mass flow ratio [-]	1.0	1.0	1.0	1.0	1.0	
Warm air - temperature [°C]	~25°C	~25°C	~25°C	~35°C	~35°C	
Warm air - humidity	wet bulb < 14 °C	45%-75%	45%-75%	50%	14-22 g/kg	
Cold air inlet - temperature [°C]	5°C	0 to -5°C	0 to -5°C	25°C	25°C	
Cold air inlet - humidity	undefined	undefined	undefined	50%	50%	
50% P <sub>nom</sub>	Temperature efficiency dry [%]	Y	N	N	Y	N
	Temperature efficiency wet [%]	N	N	Y	N	N
	Humidity efficiency	N	N	Y	Y	N
100% P <sub>nom</sub>	Temperature efficiency dry [%]	Y	N	N	Y	Y
	Temperature efficiency wet [%]	N	Y	Y	N	N
	Humidity efficiency	N	N	Y	Y	Y
150% P <sub>nom</sub>	Temperature efficiency dry [%]	Y	N	N	Y	N
	Temperature efficiency wet [%]	N	N	Y	N	N
	Humidity efficiency	N	N	Y	Y	N

Table 3: Testing point conditions for plate heat exchangers with and without humidity transfer

- For measuring the efficiency of the cross-flow exchangers, these shall be installed into the test rig diagonally, i.e. standing on edge, as it is common in practice. This shall no longer require any instructions of the manufacturer according to EN 308:1997, section 5.1.
- The pressure drop (in Pa, no decimal place, normally rounded) shall be measured in the test rig in diagonal installation, i.e. standing on edge, as it is common in practice. This shall no longer require any instructions of the manufacturer according to EN 308:1997, section 5.1. The pressure difference should be kept zero between both outgoing flows.

If any of individual points of measurement shows a deviation larger than the acceptable acceptance criteria, the failure shall be declared and the failure procedure applied. Participants shall be free to adapt their selection documentation as they like; however the penalty test should confirm the test data.

### A.5 Verification after test

After testing the performance the laboratory shall also check the plate thickness even if the unit has to be damaged. The allowed acceptance criteria is:

- Thickness of the plate : +/- 10%

### A.6 Checking specifications

When calculating the deviation between the claimed values and the measured values using the selection software under the tests conditions, Eurovent Certita Certification shall use the following inputs:

- for airflows: exhaust air inlet (1.1) and supply air outlet (2.2);

- for temperature: exhaust air inlet (1.1) and supply air inlet (2.1);
- for humidity: exhaust air inlet (1.1) and supply air inlet (2.1).

### A.7 Consistency check of the performances for multiple units

Concerning tests of heat exchangers that cannot be tested in the laboratory and built of N \* N equal modules the following shall apply (only valid for cross-flow plate heat exchangers without humidity transfer):

- 1) Calculate the efficiency and pressure drop of a single module;
- 2) The NTU value will be calculated from the single module claimed efficiency using the method described in APPENDIX A.
- 3) Unless proven to Eurovent Certita Certification the claimed efficiency of the complete unit built of N\*N equal modules shall not be higher than the one calculated using the following formula:

$$\text{Eq. 4} \quad \eta_{\text{dry}} = 1 - \exp\left(\frac{1}{C_r} (N * \text{NTU})^{0.22} (\exp(-C_r * (N * \text{NTU})^{0.78}) - 1)\right)$$

- 4) No further acceptance criteria shall be applied;
- 5) Unless proven to Eurovent Certita Certification the claimed pressure drop shall not be lower than the one calculated likewise by multiplying the claimed pressure drop of the single module by N. No further acceptance criteria shall be applied;
- 6) The wet efficiency will not be checked.

### A.8 Consistency check of the performances for combination of units

This section applies to all types of combination of two or more heat exchangers (for instance in parallel, in series, etc ...).

Unless proven to Eurovent Certita Certification, the claimed performances for these kinds of combinations shall be in line with the claimed performances of the individual heat exchangers:

- the efficiency of the combination shall not be higher than the efficiency which could be obtained using the claimed efficiencies of each individual heat exchangers. No additional acceptance criteria shall be applied.
- the pressure drops of the combination shall not be lower than the pressure drops which could be obtained using the claimed pressure drops of each individual heat exchangers. No additional acceptance criteria shall be applied.
- A combi-block exchanger shall not have a higher efficiency than the corresponding single block exchanger. Its pressure drop shall not be lower than the one of the corresponding single block exchanger calculated at half the same airflow.

### A.9 Acceptance criteria

For the test to be acceptable, the testing unit shall not differ from the declared model from more than the following acceptance criteria values:

<b>Performance</b>	<b>Acceptance criteria</b>
Dimensions	+/- 2mm
Plate spacing	+/- 1% or +/- 1 plate
Plate thickness	+/- 10%

For the test to be acceptable, leakage shall be below:

<b>Performance</b>	<b>Acceptance criteria</b>
Air leakage	+0.5% for models without humidity transfer

+1.0% for models with humidity transfer

When tested in the laboratory the obtained performance data shall be different than the acceptance criteria defined in the table below:

<b>Performance</b>	<b>Acceptance criteria</b>	<b>High Deviation</b>
Influence of pressure difference on pressure drop	+10%, at least 15 Pa	<i>N/A</i>
Pressure drop at standard conditions	+10%, at least 15 Pa	<i>+15% or +20Pa</i>
Temperature efficiency dry	-3%-point	<i>-4.5%-point</i>
Temperature efficiency wet	-5%-point	<i>-7.5%-point</i>
Humidity efficiency	-5%-point	<i>-7.5%-point</i>

## A.10 Description of the NTU method

For the NTU (Number Transfer Unit) method, the temperature effectiveness of a cross flow heat exchanger with both fluids unmixed is given by the following equation:

$$\text{Eq. 5} \quad \eta_{\text{dry}} = 1 - \exp\left(\frac{\exp(-(N \cdot \text{NTU}) \cdot C_r \cdot (N \cdot \text{NTU})^{-0.22}) - 1)}{(N \cdot \text{NTU})^{-0.22} \cdot C_r}\right)$$

$C_r$  is the dimensionless heat capacity rate ratio between the warm fluid and the cold fluid:

$$\text{Eq. 6} \quad C_r = \frac{C_{\min}}{C_{\max}}$$

Where  $C_{\min}$  and  $C_{\max}$  depends on the relative magnitudes of the hot and cold fluid heat capacity rates.

For air to air plate heat exchangers with balanced airflows it is assumed that  $C_r = 1$ .

The NTU value can be calculated with an iteration process.

Introducing

$$\text{Eq. 7} \quad \text{arg} = \left(\frac{\exp(-\text{NTU} \cdot C_r \cdot \text{NTU}^{-0.22}) - 1}{\text{NTU}^{-0.22} \cdot C_r}\right),$$

we have

$$\text{Eq. 8} \quad \eta_{\text{dry}} = 1 - \exp(\text{arg})$$

And

$$\text{Eq. 9} \quad \text{arg} = \ln(1 - \eta_{\text{dry}}).$$

We have  $C_r = 1$  and  $n_i = \text{NTU}_i^{-0.22}$  ( $i$  is the iteration index)

Therefore,

$$\text{Eq. 10} \quad \text{arg} = \frac{\exp(-\text{NTU} \cdot n_i) - 1}{n_i}$$

$$\text{Eq. 11} \quad \exp(\text{NTU} \cdot n_i) = \frac{1}{1 + n_i \cdot \text{arg}} = a_i$$

$$\text{Eq. 12} \quad \text{NTU}_i = \frac{1}{n_i} \cdot \ln(a_i)$$

To use the method, one shall start from a "step 0" value  $n_0$  (for instance 0.5), and use a dichotomy method until a negligible error value is reached (to be used:  $1.00\text{E}^{-06}$ ).

### Example:

The efficiency of the single exchanger is  $\eta_{\text{dry}} = 70\%$ . The step 0 value is taken as  $n_0 = 0.5$ .

$$\text{arg} = -1.203972804$$

$$\text{Eq. 13} \quad \text{NTU}_0 = \frac{1}{n_0} \cdot \ln(a_0) = 1.842538218$$

$$\text{Eq. 14} \quad n'_0 = \text{NTU}_0^{-0.22} = 0.874195102$$

The error is calculated as:

$$\text{Eq. 15} \quad \epsilon = \frac{\text{abs}(n_0 - n'_0)}{n_0}$$

If the error is not satisfying, a new iteration begins with

$$\text{Eq. 16} \quad n_1 = \frac{n_0 + n'_0}{2}$$

For this example, here is a table summing up the iteration process:



<b>i</b>	<b>n<sub>i</sub></b>	<b>a<sub>i</sub></b>	<b>NTU<sub>i</sub></b>	<b>n'<sub>i</sub></b>	<b>Error<sub>i</sub></b>
<b>0</b>	0,5	2,51247697	1,84253822	0,8741951	0,7483902
<b>1</b>	0,687097551	5,78860363	2,55551936	0,81349443	0,18395768
<b>2</b>	0,750295989	10,3451093	3,11412284	0,77887208	0,03808643
<b>3</b>	0,764584035	12,5846927	3,31223396	0,76837527	0,00495856
<b>4</b>	0,766479653	12,9568348	3,34206319	0,76686122	0,00049782
<b>5</b>	0,766670436	12,9955115	3,34511924	0,76670703	4,7736E-05
<b>6</b>	0,766688735	12,9992332	3,34541289	0,76669223	4,5554E-06
<b>7</b>	0,766690481	12,9995885	3,34544092	0,76669081	4,3452E-07

Table 4: Result of the iteration process for calculating NTU

The table below provides the NTU values for a given set of dry efficiencies of single modules and the corresponding maximum dry efficiencies allowed for a unit built of N\*N modules with N=2.

<b>η<sub>dry</sub></b>	<b>NTU</b>	<b>2*NTU</b>	<b>η<sub>dry</sub> max (N=2)</b>
5%	0,054	0,108	9,4%
10%	0,1154	0,2308	17,9%
15%	0,1853	0,3706	25,7%
20%	0,2651	0,5302	32,8%
25%	0,3569	0,7138	39,2%
30%	0,4635	0,927	45,1%
35%	0,5889	1,1778	50,5%
40%	0,7388	1,4776	55,5%
45%	0,9215	1,843	60,0%
50%	1,15	2,3	64,1%
55%	1,4456	2,8912	67,9%
60%	1,8458	3,6916	71,3%
65%	2,4242	4,8484	74,6%
70%	3,3454	6,6908	77,7%
75%	5,0486	10,0972	81,0%
80%	8,86	17,72	84,8%
85%	18,37	36,74	89,0%
90%	44,3	88,6	93,2%
95%	146,5	293	96,9%
99%	1035	2070	99,5%

Table 5: Example of NTU values and the corresponding maximum allowed dry efficiencies for Cr = 1 and N=2

## APPENDIX B. CERTIFICATION PROCESS AND SCHEDULE

### B.1 Admission procedure

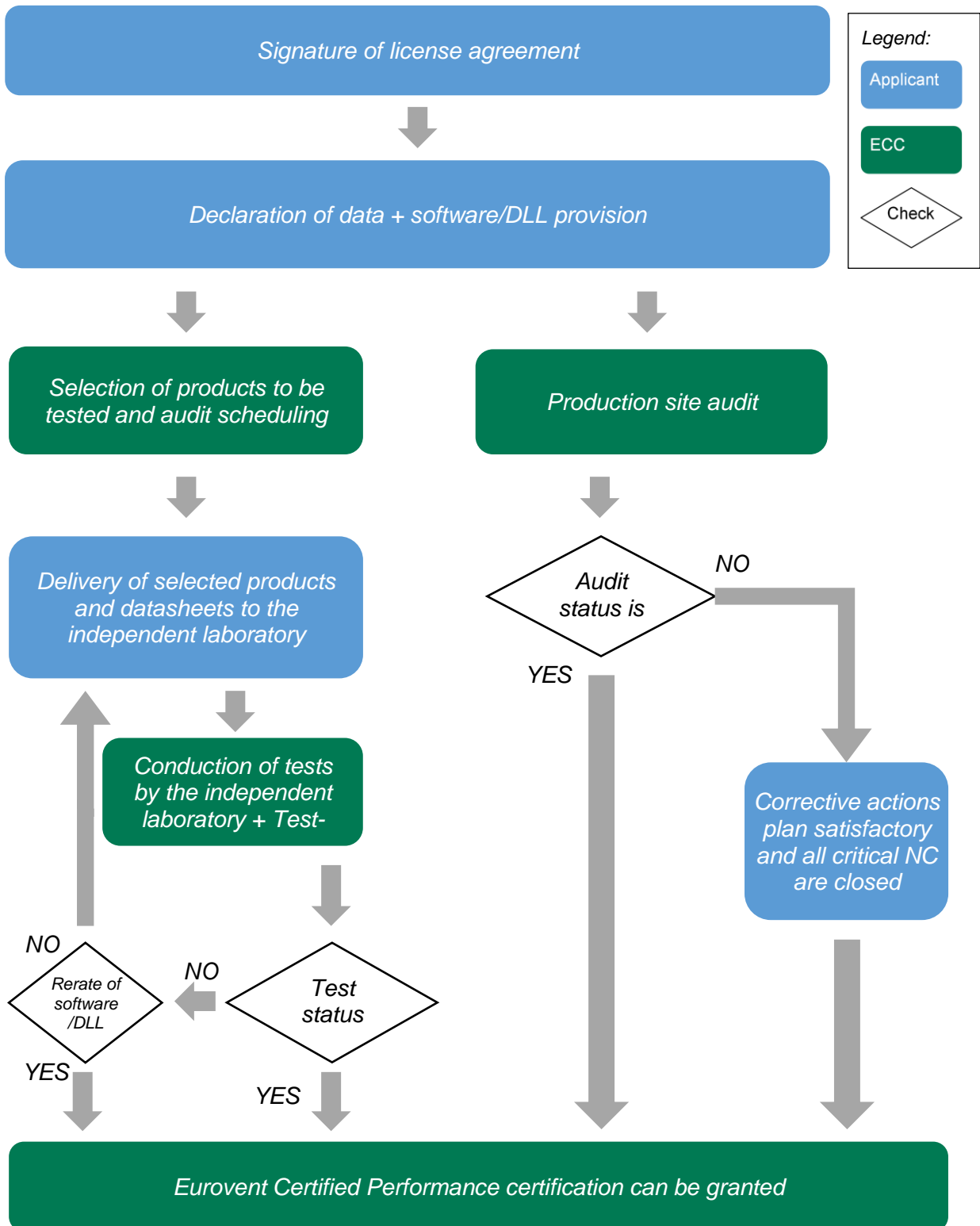

## B.2 Surveillance procedure

Certification step	Deadline (For information only)
Eurovent Certita Certification asks for update of list and software from the Participant and sends the notification(s)/invoice(s) for the audits in all factories.	<i>15/04/n</i>
The participant sends the updated declaration file as well as the software/DLL	<i>15/05/n</i>
Eurovent Certita Certification sends the list of selected models to the participant (regular tests + penalty tests from the previous test campaign)	<i>15/06/n</i>
Selection list is confirmed	<i>31/08/n</i>
Delivery + Technical data sheet + payments are completed for all tests.	<i>30/11/n</i>
All first tests finished by the laboratory	<i>28/02/n+1</i>
Diploma validity	<i>Q<sup>1</sup>(n+1)+3 months</i>
Eurovent Certita Certification sends test results (software checking)	<i>30/03/n+1</i>
Eurovent Certita Certification sends selection list for second test	<i>30/04/n+1</i>
Correction of the software after failure	<i>1 month</i>

---

<sup>1</sup> Quarter of the audit

## APPENDIX C. LABORATORY LIMITS

### C.1 For “usual” units

Air flow rates: **1500 m<sup>3</sup>/h – 7000 m<sup>3</sup>/h**

Dimensions for large test units:

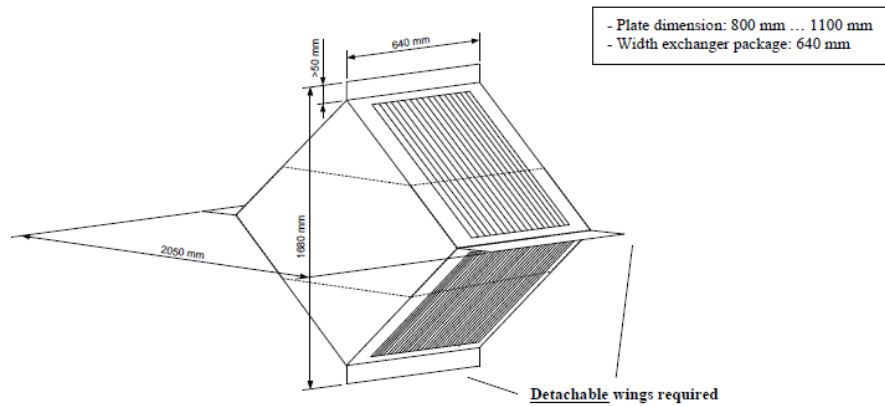

Dimensions for smaller test units:

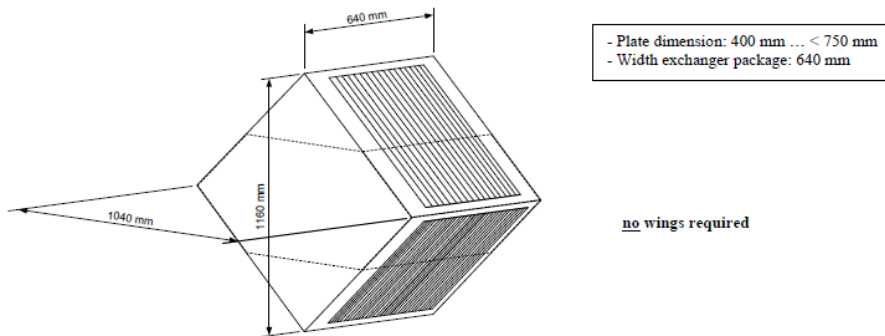

In both drawings the counter flow heat exchanger is shown in dashed lines. For the counter flow heat exchanger the same horizontal dimensions are possible as for the cross flow heat exchanger. The height of the counter flow heat exchanger is lower than of the cross flow heat exchanger anyway. For the large units the counter flow heat exchanger has to be equipped with two detachable wings.

### C.2 For small units

Air flow rates: **up to 1'000 m<sup>3</sup>/h**

Dimensions for test units:

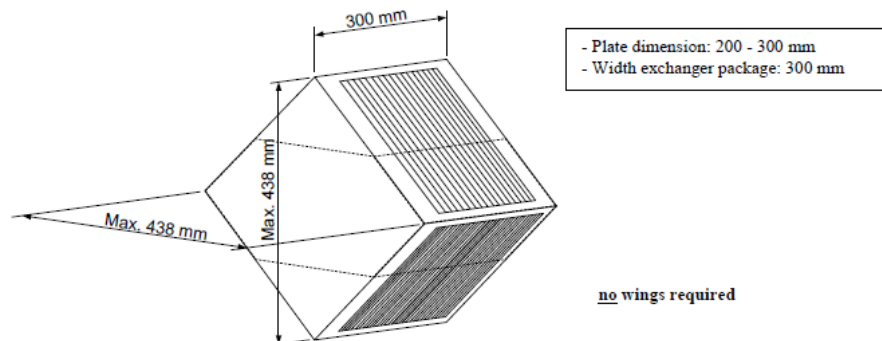

The counter flow heat exchanger is shown in dashed lines. For the counter flow heat exchanger the same horizontal dimensions are possible as for the cross flow heat exchanger. The height of the counter flow heat exchanger is lower than of the cross flow heat exchanger anyway.

## APPENDIX D. FORMS

### D.1 Form AAHE-1: Declaration file

The form AAHE-1 (declaration file to be filled in shall be sent by Eurovent Certita Certification to:

- applicants who have signed the license agreement;
- participants on an annual basis before the deadline specified in the certification schedule.

A template will be available for information and upon request.

### D.2 Form AAHE-2: Technical data sheet (TDS)

The form AAHE-2 (Technical Data Sheet) to be filled in shall be sent by Eurovent Certita Certification to Applicants/Participants who have returned the form AAHE-1 duly completed.

A template will be available for information and upon request.

### D.3 Form AAHE-3: Software/DLL update record sheet

The form AAHE-3 shall be sent by the Applicant/Participant before any new version of the software is validated by Eurovent Certita Certification.

**Company Name**

**XXXXX Software Name**

### AHU Software Update Record Sheet

Prepared By:

Date: [Click here to enter a date.](#)

Software Revision	Date	Brief Description of update	Effect on software ECC Certified performance (Y/N)
		For instance: Logo update	Yes <input type="checkbox"/> No <input type="checkbox"/>
		Prices	Yes <input type="checkbox"/> No <input type="checkbox"/>
		Dll...	Yes <input type="checkbox"/> No <input type="checkbox"/>
			Yes <input type="checkbox"/> No <input type="checkbox"/>

Signature:

## APPENDIX E. VOCABULARY

The use of recommended and accepted wordings may only take place in accordance with the symbols and equations listed in the Table below.

SYMBOL	FORMULA	RECOMMENDED	ACCEPTED	FORBIDDEN
t		Temperature <sup>(1)</sup>		
x		Absolute humidity <sup>(1)</sup>	Humidity Moisture contents <sup>(1)</sup> Moisture <sup>(2)</sup>	
h		Total enthalpy <sup>(3)</sup>	Specific enthalpy <sup>(3)</sup> Enthalpy <sup>(2)</sup>	
...11		Extract air [if Exhaust air is used] Exhaust air inlet <sup>(1)</sup> [if Exhaust air outlet is used]	Exhaust air in [if Exhaust air out is used] Exhaust air entering <sup>(2)</sup>	
...21		Supply air inlet <sup>(1)</sup>	Supply air in Supply air entering <sup>(2)</sup> Fresh air	
...12		Exhaust air [if Extract air is used] Exhaust air outlet <sup>(1)</sup> [if Exhaust air inlet is used]	Exhaust air out [if Exhaust air in is used] Exhaust air leaving (2)	
...22		Supply air outlet <sup>(1)</sup>	Supply air out Supply air leaving <sup>(2)</sup> Supply air [if Fresh air is used]	
...w		Wet bulb <sup>(1)</sup>		
...d		Dry bulb <sup>(2)</sup>		
Q <sub>HRS</sub>		Capacity of the heat recovery system	Capacity of the HRS <sup>(3)</sup> HRS capacity Recuperation power	
P <sub>el</sub>		Electric power consumption <sup>(3)</sup>		
η <sub>t</sub> <sup>(*)</sup>	$\eta_t = \frac{t_{22} - t_{21}}{t_{11} - t_{21}}$	Temperature efficiency dry <sup>(*)</sup> [for plates]	Temperature ratio dry <sup>(*)</sup> [for plates]	Efficiency [without Temperature or Sensible or Latent in front]
		Temperature efficiency wet <sup>(*)</sup> [for plates]	Temperature ratio wet <sup>(*)</sup> [for plates]	
		Temperature efficiency <sup>(*)</sup> [for rotaries]	Temperature ratio <sup>(*)</sup> <sup>(1)</sup> [for rotaries]	Ratio [without Temperature in front]

				Temperature efficiency [for plates, without dry or wet after]
				Temperature ratio [for plates, without dry or wet after]
			Sensible efficiency <sup>(*)</sup>	
			Latent efficiency <sup>(*)</sup>	
$\eta_x^{(*)}$	$\eta_x = \frac{x_{22} - x_{21}}{x_{11} - x_{21}}$	Humidity efficiency <sup>(*)</sup>	Humidity ratio <sup>(*) (1)</sup>	
$\eta_h$	$\eta_h = \frac{h_{22} - h_{21}}{h_{11} - h_{21}}$	Total efficiency	Total ratio	
			Enthalpy efficiency	
			Enthalpy ratio	
		Sensible effectiveness dry [for plates]	Temperature effectiveness dry [for plates]	Effectiveness [without Temperature or Sensible in front]
		Sensible effectiveness wet [for plates]	Temperature effectiveness wet [for plates]	
$\epsilon_t$	$\epsilon_t = \frac{\dot{m}}{\dot{m}_{min}} \cdot \frac{t_{22} - t_{21}}{t_{11} - t_{21}}$			Temperature effectiveness [for plates, without dry or wet after]
		Sensible effectiveness <sup>(4)</sup> [for rotaries]	Temperature effectiveness [for rotaries]	
				Sensible effectiveness [for plates, without dry or wet after]
$\epsilon_x$	$\epsilon_x = \frac{\dot{m}}{\dot{m}_{min}} \cdot \frac{x_{22} - x_{21}}{x_{11} - x_{21}}$	Latent effectiveness <sup>(4)</sup>	Humidity effectiveness	
$\epsilon_h$	$\epsilon_h = \frac{\dot{m}}{\dot{m}_{min}} \cdot \frac{h_{22} - h_{21}}{h_{11} - h_{21}}$	Total effectiveness <sup>(4)</sup>	Enthalpy effectiveness	
			Total heat effectiveness	
$\eta_e$	$\eta_e = \eta_t \cdot (1 - 1/\epsilon)$	Energy efficiency (always defined for balanced airflows.)	Energetic efficiency	Efficiency <sup>(3)</sup> [without Energy or Energetic in front]
$\epsilon$	$\epsilon = Q_{HRS}/P_{el}$	Coefficient of performance <sup>(3)</sup>		

## REFERENCES:

1. CEN/TC 110. EN308:1997: Heat exchangers - Test procedures for establishing the performance of air to air flue gases heat recovery devices. 1997.



2. ASHRAE. ASHRAE Handbook - HVAC systems and equipment; Chap. 44: Air-to-air energy recovery. 2000.
3. CEN/TC 156. EN13053:2006/A1:2011: Ventilation for buildings - Air handling units - Rating and performance for units, components and sections. 2011.
4. ASHRAE/TC 5.5. ASHRAE/ANSI 84: Method of testing air-to-air heat exchangers. 1991.





Performances on line  
[www.eurovent-certification.com](http://www.eurovent-certification.com)

**EUROVENT CERTITA CERTIFICATION**  
48-50 Rue de la Victoire, 75009 Paris, FRANCE  
Phone: +33 (0)1 7544 7171  
[www.eurovent-certification.com](http://www.eurovent-certification.com)

